

# Package Outlines

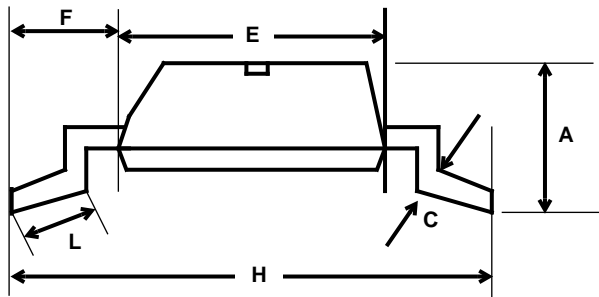
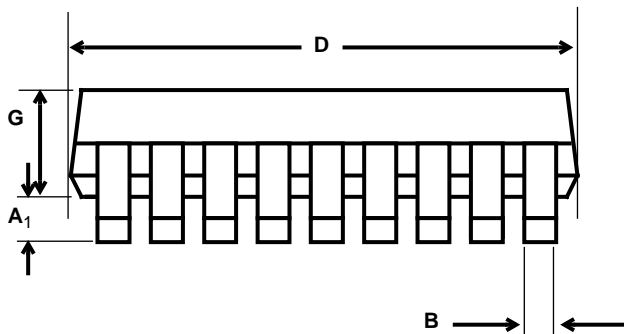
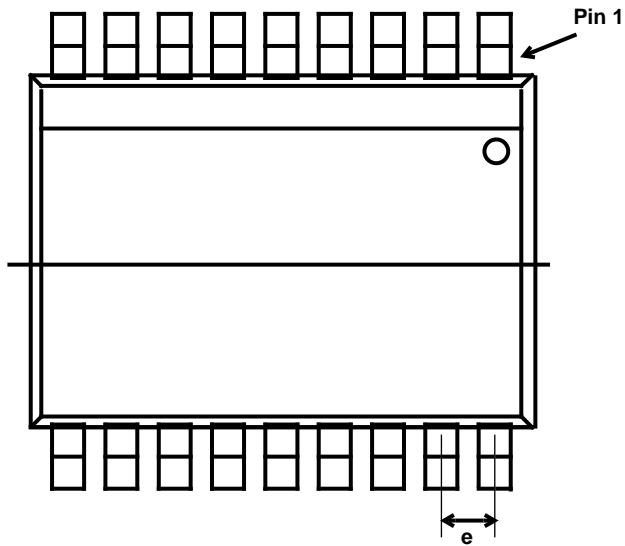

**Notes:**

- 1) Not to scale
- 2) Dimensions in inches
- 3) (Dimensions in millimeters)
- 4) Ref. JEDEC Standard M0-153
- 5) A & B Maximum dimensions include allowable mold flash

Dim	20-Pin		24-Pin		28-Pin	
	Min	Max	Min	Max	Min	Max
A		0.047 (1.2)	-	0.047 (1.2)		0.047 (1.2)
A <sub>1</sub>		0.0039 (0.1)		0.0039 (0.1)		0.0039 (0.1)
B	0.0075 (0.19)	0.012 (0.3)	0.0075 (0.19)	0.012 (0.3)		0.012 (0.3)
C	0.0035 (0.09)	0.0079 (0.2)	0.0035 (0.09)	0.0079 (0.2)		0.0079 (0.2)
D	0.252 (6.4)	0.26 (6.6)	0.30 (7.7)	0.311 (7.9)	0.377 (9.6)	0.386 (9.8)
E	0.17 (4.3)	0.177 (4.5)	0.17 (4.3)	0.177 (4.5)	0.17 (4.3)	0.177 (4.5)
e	0.025 BSC (0.65 BSC)		0.025 BSC (0.65 BSC)		0.025 BSC (0.65 BSC)	
F	0.039 REF (1.0 REF)		0.039 REF (1.0 REF)		0.039 REF (1.0 REF)	
G	0.03 (0.8)	0.041 (1.05)	0.03 (0.8)	0.041 (1.05)	0.03 (0.8)	0.041 (1.05)
H	0.252 BSC (6.4 BSC)		0.252 BSC (6.4 BSC)		0.252 BSC (6.4 BSC)	
L	0.02 (0.5)	0.029 (0.75)	0.02 (0.5)	0.029 (0.75)	0.02 (0.5)	0.029 (0.75)

Thin Small Shrink Outline Package (TSSOP) - N Suffix